

UV Monitor Biotage® Flash 150/400

Fiber Optic UV Monitor System

Reduce Process Risk, Increase Confidence, Even Better Fraction Collection

We combine a robust, reliable UV (Visible/Ultraviolet absorbance detector) monitor with a specialized wireless tablet optimized for use in sensitive* environments. The Biotage UV Monitor kit features the latest in fiber optic technology and a powerful SW package to provide the most effective and flexible UV monitoring system for Biotage® Flash 150 and Biotage® Flash 400 purification systems.

This UV Monitor has been designed for Biotage Industrial Flash Systems and contains one of the smallest Flash Purification UV monitors in the industry.

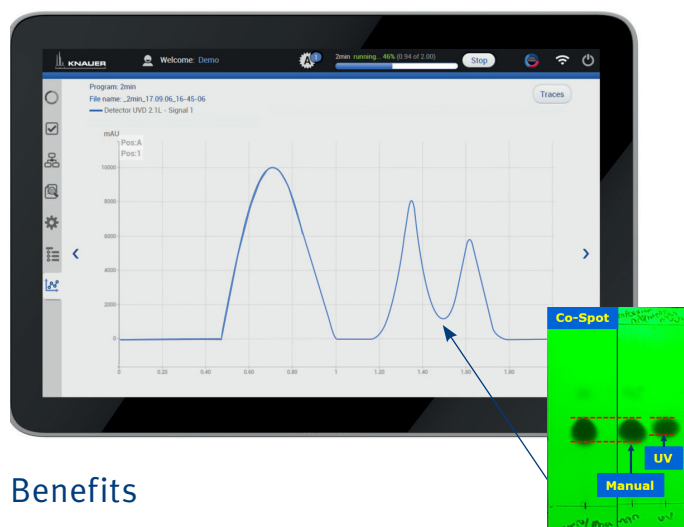

Benefits

- » Simple in-line system.
- » Easily retrofit to existing Biotage Flash 150 or Flash 400 production scale systems.
- » Simplify purification.
- » Improve fraction purity, reduce solvent usage, and reduce fraction volume evaporation.
- » Increased safety; minimize handling of fractions containing HP-API's.

*Normal ATEX risk assessment applies. The detector should not be kept in the same environment as the Flash system. Supplied as standard, this kit contains fiber optic cables that are long enough to site the detector in a separate environment to the flash system. Longer fiber optic cables are available as optional accessories. If the detector is to be kept in the immediate environment as the Flash System, an ATEX Box must be used. An ATEX classed PC Tablet is included by Biotage for use with the UV monitor kit. **Please see user guide for full details.**

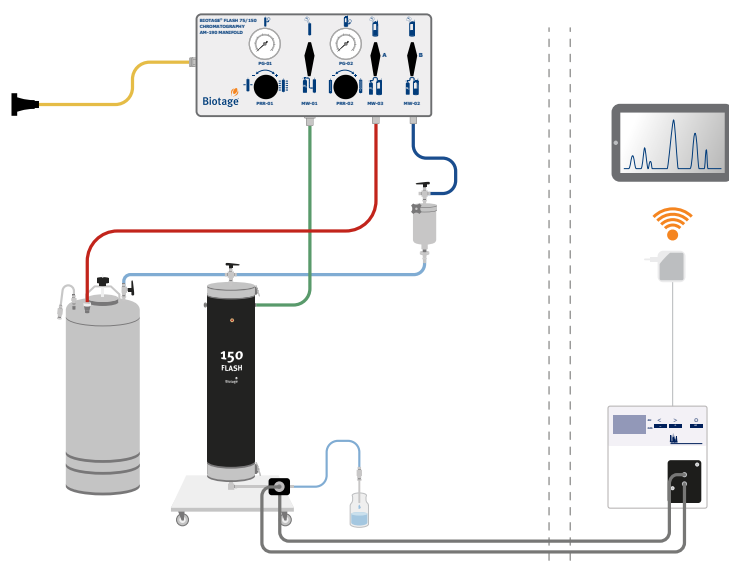

Features

UV Monitor

- » Auto error check and calibration on start up.
- » LED read out for simplified non-wireless configuration.
- » Easily upgradeable and future proof.
- » Wavelength: 190–500 nm (individually selectable).

Flow Cell

- » Specialized for preparative flash purification applications, up to 10 L/min.
- » Built in an automatic flow splitting function.
- » Available in two sizes (for 0.25 inch and 0.5 inch tubing), each flow cell has an adjustable path length (0.5, 1.25, 2 mm).

Tablet /Control SW

- » Automatic recognition and storage of device-specific information, important for Good Laboratory Practice and Instrument Qualification.
- » ATEX Class II/22.
- » Remote monitoring and control.
- » Automatic and current diagnosis of the device.
- » Remote wavelength change possible.
- » Audit trail and save data files securely.

Compatibility

Significantly enhance the power of existing Biotage Flash purification systems.

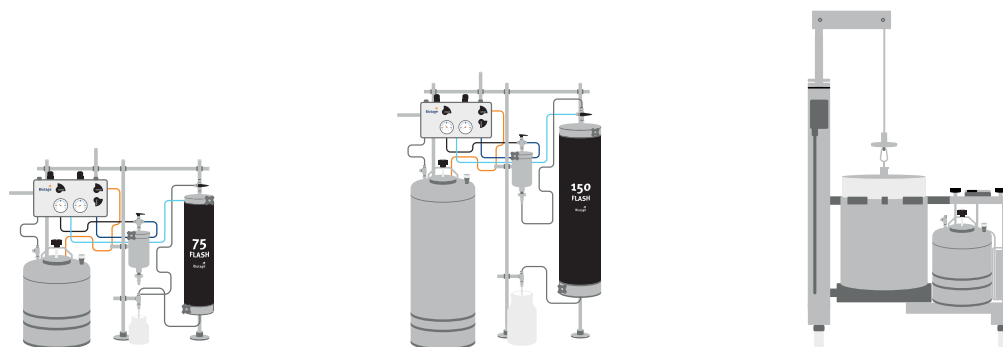

	Biotage® Flash 75	Biotage® Flash 150	Biotage® Flash 400
Sample Size	40 g–100 g	250 g–500 g	2 Kg–8 Kg
Cartridge Size	400 g, 800 g	2.5 Kg, 5 Kg	20 Kg, 40 Kg
Modular Design	•	•	•
UV Monitor	Option*	Option	Option
Fraction Collection	Manual	Manual	Manual

• = Yes

*Also possible to connect to Biotage® Flash 75 systems, enquire for details.

Ordering Information

Part Number	Description	Pack Size
UV-FL150	UV Monitor for Biotage® FLASH 150 system	1
UV-FL400	UV Monitor for Biotage® FLASH 400 system	1
UV-UPGRD FL150/400	UV Monitor upgrade for Biotage® Flash 400 (from 150)	1
416238SP	Stray Light Filter	1
416239SP	Flow Cell, 2 mm, 1/4" SS for Biotage® Flash 75/150 systems	1
416240SP	Flow Cell, TriClamp, 2 mm, 1/2" SS for Biotage® Flash 400 systems	1
416241SP	3M Fiber optic cable	2
416242SP	5M Fiber optic cable	2
416243SP	10M Fiber optic cable	2

EUROPE

Main Office: +46 18 565900
 Toll Free: +800 18 565710
 Fax: +46 18 591922
 Order Tel: +46 18 565710
 Order Fax: +46 18 565705
 order@biotage.com
 Support Tel: +46 18 56 59 11
 Support Fax: + 46 18 56 57 11
 eu-1-pointsupport@biotage.com

NORTH & LATIN AMERICA

Main Office: +1 704 654 4900
 Toll Free: +1 800 446 4752
 Fax: +1 704 654 4917
 Order Tel: +1 704 654 4900
 Order Fax: +1 434 296 8217
 ordermailbox@biotage.com
 Support Tel: +1 800 446 4752
 Outside US: +1 704 654 4900
 us-1-pointsupport@biotage.com

JAPAN

Tel: +81 3 5627 3123
 Fax: +81 3 5627 3121
 jp_order@biotage.com
 jp-1-pointsupport@biotage.com

CHINA

Tel: +86 21 68162810
 Fax: +86 21 68162829
 cn_order@biotage.com
 cn-1-pointsupport@biotage.com

KOREA

Tel: + 82 31 706 8500
 Fax: +82 31 706 8510
 korea_info@biotage.com
 kr-1-pointsupport@biotage.com

Distributors in other regions
 are listed on www.biotage.com

Part Number: PPS482.v2

© 2024 Biotage. All rights reserved. No material may be reproduced or published without the written permission of Biotage. Information in this document is subject to change without notice and does not represent any commitment from Biotage. E&OE. A list of all trademarks owned by Biotage AB is available at www.biotage.com/legal. Other product and company names mentioned herein may be trademarks or registered trademarks and/or service marks of their respective owners, and are used only for explanation and to the owners' benefit, without intent to infringe.